

SIGNAL ISOLATORS

Single Output Type B12-SI
Dual Output Type B12-SI/2

User Guide

Continuous development may necessitate
changes in these details without notice

Document Ref: udb12-SI.vp Rev 0



PROCESS MEASUREMENT, CONTROL & DISPLAY INSTRUMENTATION

STROUD INSTRUMENTS LTD

36-40 Slad Road, Stroud, Gloucestershire GL5 1QW England

Tel: +44 (0)1453 765433 Fax: +44 (0)1453 764256

sales@sil.co.uk <http://www.sil.co.uk>



WARNING!

It is important that this guide is read and fully understood before attempting installation or commissioning of the instrument. Instructions appearing in this document, and current safety legislation, must be observed to ensure personal safety and to prevent damage to the instrument or equipment connected to it.

The instrument should be installed, commissioned and operated *only* by suitably qualified and authorised personnel.

Safety and EMC information

Safety: EN61010 -1

Immunity: EN50082-1

Emissions: EN50081-1

CE certified



The specifications for the instrument must not be exceeded. If the instrument is used in a manner not specified, the protection provided by the instrument may be compromised.



The instrument must be installed in an enclosure that provides adequate protection against electric shock.



Ensure that power to the instrument is switched off and signal wiring isolated from hazardous voltages before carrying out installation or maintenance.



The instrument is designed for installation in a clean, dry environment (Pollution degree 1).





Stroud Instruments Ltd strongly recommends that repairs and re-calibration work are done on a return to factory basis in order that our quality standards, product specifications and safety precautions are not compromised.



The instrument is double insulated

Note: Clean with a moist cloth - USE NO SOLVENTS.

Installation

-  **WARNING:** Installation should be conducted by appropriately skilled and authorised personnel only.
-  **WARNING:** Ensure that power to the instrument is switched off and signal wiring isolated from hazardous voltages before carrying out installation.
-  **WARNING:** The instrument must be installed in an enclosure that provides adequate protection against electric shock.

Location

- The instrument is designed for installation in a clean, dry environment
- Do not install near to switch gear, motor controllers or other sources of strong magnetic fields.
- Avoid exposure to direct sunlight and ensure the ambient temperature inside the enclosure that the unit is mounted in will not exceed our specification.

Fixing

B12 Series Modules are designed to be fitted to a flat dry surface using two 4mm screws. Alternatively, by fitting an optional DIN clip, they may be clipped to a rail conforming to BS5584:1978, EN50 022, DIN46277-3.

Grommets are provided on three sides of the base section and there are two rear entry knock outs in the bottom.

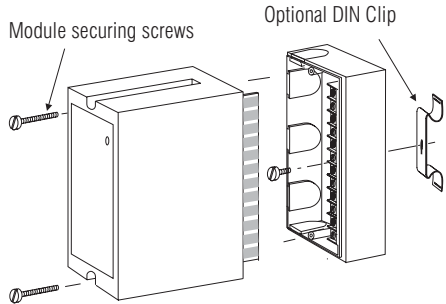

Dimensions and fixing positions

Depth of unit 106mm

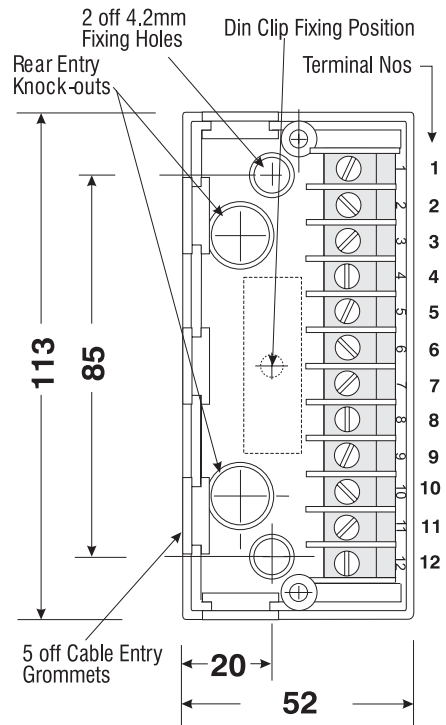

Wiring and connections

- Segregate power supply and signal wiring.
- Use screened cable for all signal wiring with the screen earthed at one end only.
- All connections should be made using ferrules.

Screw terminals are provided - wire capacity 2 x 1.5mm² (approx. 16 AWG).

Access to Terminals

WARNING: Ensure that power to the instrument is switched off and signal wiring isolated from hazardous voltages. Loosen the two module securing screws. Gently pull away the top section of the module from its base to expose the fixing points and wiring terminals. To refit the module, align the module edge connectors with the socket in the base and carefully press home. **NB** do not over tighten the module securing screws.

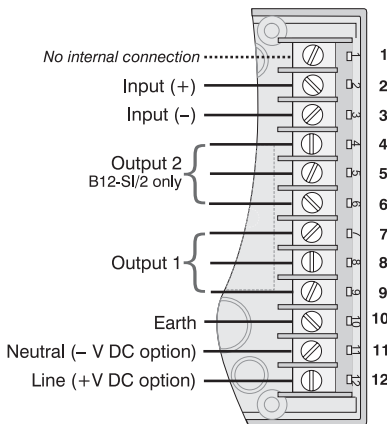

NOTE: Units with mA inputs are supplied with a component connected between terminals 2 and 3. This maintains the signal loop when the instrument is unplugged from its base section.

Input connections

Inputs are configured during manufacture to suit the application specified - see *data label on enclosure*. A change in the type of input from voltage to current or vice versa will require a return to factory for re-configuration.

Voltage and mA

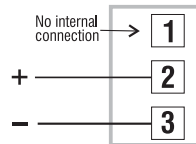

Output connections

Outputs are configured during manufacture to suit the application specified - see *data label on enclosure*. A change in the type of output will require a return to factory for re-configuration. **NB** Output 2 is available on the dual output B12-SI/2 only.

Voltage output 1

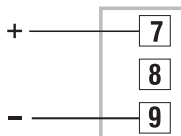

Voltage output 2

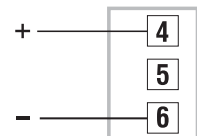

Current output 1

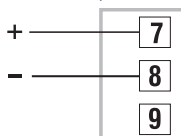

Current output 2

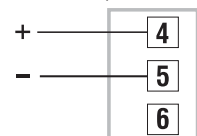

Current sink output 1

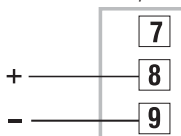

Current sink output 2

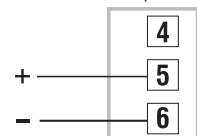

Power supply connections

This instrument is supplied in *one* of two power supply versions.

1. AC mains supply - either 230V, 220V or 110V, 50/60Hz, 3VA.
2. Low voltage option - accepts 11-32 VDC, 4W or 12-24VAC



WARNING: Check that the supply voltage on the data label (on top of instrument) is suitable for the application.



WARNING: Ferrules must be used for AC mains power wiring

Power supply wiring to the instrument should be protected by a suitable fuse and double pole switch - see below. The switch should be clearly marked as the isolating switch for the instrument.

AC Mains

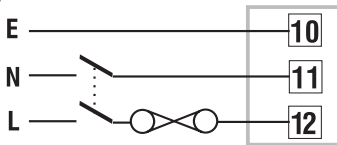

Low voltage

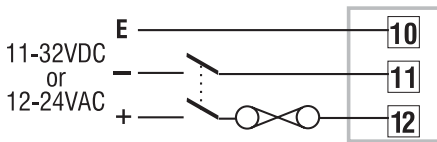

Please note:

The unit cannot be changed by the user from one type of power supply version to another. This conversion can only be done on a return to factory basis.

Span and Zero adjustment

The instrument is supplied accurately calibrated (*see specification*), therefore under normal circumstances adjustments to Span and Zero are not required. The Span and Zero controls, accessed through the holes in the front panel, will enable small adjustments to the specified calibration (*see the data label on the enclosure*) to be made.

- (i) **Set output Zero:** with the input signal at its zero setting, monitor the output signal with a suitable instrument and adjust the zero control.
- (ii) **Set output Span:** with the input at full scale adjust the span control.
- (iii) Repeat steps (i) and (ii) readjusting if necessary.

Fuse replacement and supply voltage adjustments

Gaining access to power supply



WARNING: Switch off all supplies and isolate signal and other wiring from dangerous voltages before proceeding.

- (i) Remove plug-in module as described in Access to Terminals in the Installation section.
- (ii) The plate with the terminal connections label can now be removed by easing apart the longer sides of the module to release the interlocking tongue and groove.
- (iii) Note the location of the printed circuit board(s) which must be replaced in the same position. Slide out the board(s).

Changing AC supply voltage

Mains powered units can be adapted for operation on 110V, 220V or 230V supplies. Fig 1 provides details of the required link settings which are effected by soldered tinned copper wire links.



WARNING: Links for 110V and 220V operation must be insulated with silicon rubber sleeving.

Fuse replacement

The fuse holder is located at the edge of the circuit board adjacent to the mains transformer or low voltage power unit.

Fuse size: 20mm x 5mm dia.

Fuse ratings: AC - 100mA Quick Blow
Low Voltage - 250mA Anti-surge

Re-assembly - Type B12-SI

- (i) Re-check your link selections.
- (ii) Replace the circuit board into the case ensuring that it is located in the slot under the LED indicator window.
- (iii) Replace the bottom plate by first engaging the side with the two tongues into the slots in the case and then press the plate home to engage the side with the single tongue.
- (iv) Plug the reassembled module into the base section and secure with the two captive screws provided - *do not overtighten*.

Re-assembly - Type B12-SI/2

IMPORTANT !

The dual output isolator type B12-SI/2 has two circuit boards. Re-assembly is generally as for the B12-SI but the top edges of the PCBs (i.e. those entering the enclosure first) must be aligned and slid into the enclosure together.

Fig. 1 AC mains supply links

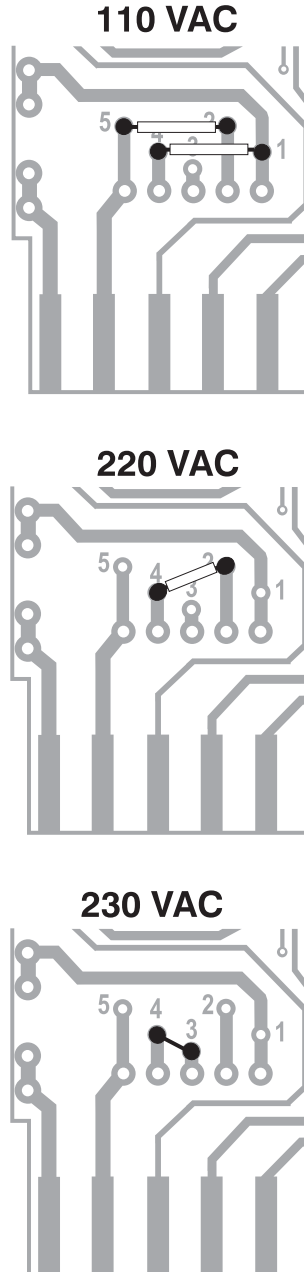

Specification

INPUT

0-10 mA into 100 ohms

0-20 mA into 50 ohms

4-20 mA into 62 ohms

0-5v into greater than 200 k ohms

1-5v into greater than 200 k ohms

N.B. Inputs other than those listed can be catered for.

OUTPUTS

0-10 mA into 1200 ohms max.

0-20 mA into 600 ohms max.

4-20 mA into 600 ohms max.

0-5v into 500 ohms minimum

1-5v into 500 ohms minimum

Current sink 4-20mA @ 50 volts max.

ISOLATION

The input and output(s) are isolated from each other and from the power supply.

Maximum Voltage 250V RMS or 400V DC

Resistance between input, output(s) or power supply

$\geq 50 \times 10^6$ ohms measured at 1000V DC.

CALIBRATED ACCURACY

Set at 100% to be within $\pm 0.1\%$ FSD

LINEARITY ERROR

$\leq \pm 0.1\%$ FSD

SUPPRESSION / ELEVATION ERROR

$\leq \pm 0.1\%$ FSD

OUTPUT RIPPLE

$\leq 0.2\%$ RMS of FSD

LOAD RESISTANCE EFFECT

$\leq 0.001\%$ of span / 100 ohm change

STABILITY

Over 24 hours $\pm 0.1\%$ FSD

Over 1 year $\pm 0.25\%$ FSD

INTERFERENCE REJECTION

Filtering is incorporated to attenuate R.F. and other industrial noise.

SERIES MODE AC REJECTION RATIO

For 50/60Hz series mode signals with p.t.p. amplitude \leq input; rejection ratio greater than 40dB.

RESPONSE TIME

1 sec as standard.

COMMON MODE REJECTION

$<0.2\%$ error for 250V RMS 50/60 Hz, or 400V DC, common mode signals.

INPUT OVERRANGE PROTECTION

Voltage Inputs: 250 volts RMS or DC

Current Inputs: 50mA

TEMPERATURE COEFFICIENTS

Zero: $\pm 0.02\%$ span / $^{\circ}\text{C}$

Span: $\pm 0.02\%$ span / $^{\circ}\text{C}$

TEMPERATURE RANGE

Operating: -10°C to $+60^{\circ}\text{C}$

Storage: -20°C to $+70^{\circ}\text{C}$

SUPPLY VOLTAGE REJECTION

Span change: $<0.02\%$ span / % supply change.

WEIGHT

Approx. 0.5kg

SAFETY & EMC

Safety: EN61010-1

Immunity: EN50082-1

Emissions: EN50081-1

CE certified