

**SIGNAL CONVERTER  
(RATE OF CHANGE MONITOR)  
Type 107-18  
User Guide**

Continuous development may necessitate  
changes in these details without notice

Document Ref: ud107-18 Rev 0



PROCESS MEASUREMENT, CONTROL & DISPLAY INSTRUMENTATION

**STROUD INSTRUMENTS LTD**

36-40 Slad Road, Stroud, Gloucestershire GL5 1QW England

Tel: +44 (0)1453 765433 Fax: +44 (0)1453 764256

sales@sil.co.uk <http://www.sil.co.uk>



## **WARNING!**

**It is important that this guide is read and fully understood before attempting installation or commissioning of the instrument. Instructions appearing in this document, and current safety legislation, must be observed to ensure personal safety and to prevent damage to the instrument or equipment connected to it.**

**The instrument should be installed, commissioned and operated *only* by suitably qualified and authorised personnel.**

## **Safety and EMC information**

Safety: EN61010 -1

Immunity: EN50082-1

Emissions: EN50081-1

CE certified



The specifications for the instrument must not be exceeded. If the instrument is used in a manner not specified, the protection provided by the instrument may be compromised.



The instrument must be installed in an enclosure that provides adequate protection against electric shock.



Ensure that power to the instrument is switched off and signal wiring isolated from hazardous voltages before carrying out installation or maintenance.



The instrument is designed for installation in a clean, dry environment (Pollution degree 1).



Stroud Instruments Ltd strongly recommends that repairs and re-calibration work are done on a return to factory basis in order that our quality standards, product specifications and safety precautions are not compromised.



The instrument is double insulated

Note: Clean with a moist cloth - USE NO SOLVENTS.

# Installation



**WARNING:** Installation should be conducted by appropriately skilled and authorised personnel only.



**WARNING:** Ensure that power to the instrument is switched off and signal wiring isolated from hazardous voltages before carrying out installation.



**WARNING:** The instrument must be installed in an enclosure that provides adequate protection against electric shock.

## Location

- The instrument is designed for installation in a clean, dry environment
- Do not install near to switch gear, motor controllers or other sources of strong magnetic fields.
- Avoid exposure to direct sunlight and ensure the ambient temperature inside the enclosure that the unit is mounted in will not exceed our specification.

## Fixing

107 Series Modules are designed to be fitted to any flat dry surface using two 4mm screws. Alternatively, by fitting an optional DIN clip, they may be clipped to a rail conforming to BS5584:1978, EN50 022, DIN46277-3. Grommets are provided on three sides of the base section and there are two rear entry knock outs in the bottom.

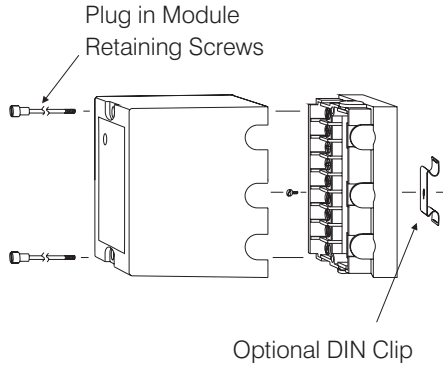

## Dimensions in mm

Module height 95mm, units with dial 117mm

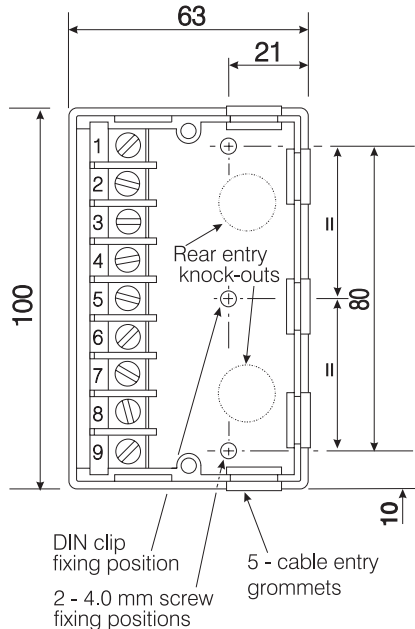

## Wiring and connections

- Segregate power supply and signal wiring.
- Use screened cable for all signal wiring with the screen earthed at instrument end only.
- All connections should be made using ferrules.

Screw terminals are provided - wire capacity 2 x 1.5mm<sup>2</sup>

### Access to Terminals

**WARNING:** Ensure that power to the instrument is switched off and signal wiring isolated from hazardous voltages

Loosen the two module securing screws. Gently pull away the top section of the module from its base to expose the fixing points and wiring terminals. To refit the module, align the module edge connectors with the socket in the base and carefully press home. **NB** do not over tighten the module securing screws.

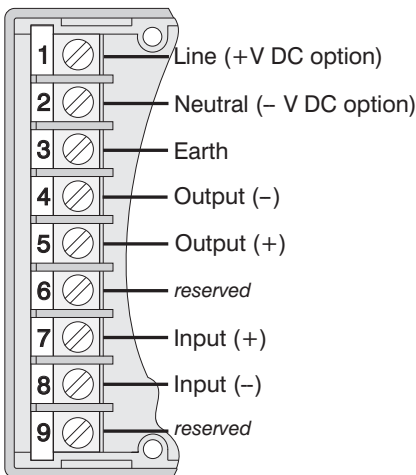

## Input connections

Inputs are configured during manufacture to suit the application specified. A change in the type of input from voltage to current or vice versa will require a return to factory for re-configuration.

### Voltage and mA

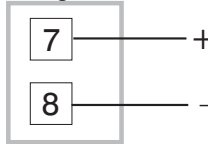

## Output connections

Outputs are configured during manufacture to suit the application specified. A change in the type of output will require a return to factory for re-configuration.

### Voltage and current

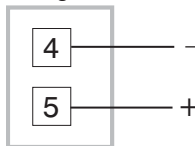

### Current sink

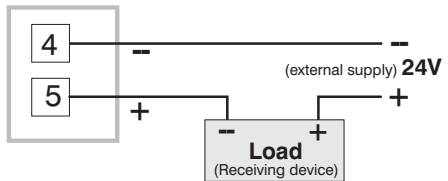

## Power supply connections

This instrument is supplied in *one* of two power supply versions.

1. AC mains supply: 110, 200, 220 or 240 VAC  $\pm 10\%$  50/60Hz; 5VA
2. DC supply: 12, 24 or 48V -10% to +20%; 3.5W



**WARNING:** Check that the supply voltage on the data label (on side of instrument) is suitable for the application.



**WARNING:** Ferrules must be used for AC mains power wiring

Power supply wiring to the instrument should be protected by a suitable fuse and double pole switch - see below. The switch should be clearly marked as the isolating switch for the instrument.

### AC Mains

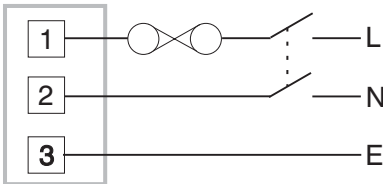

### DC supply

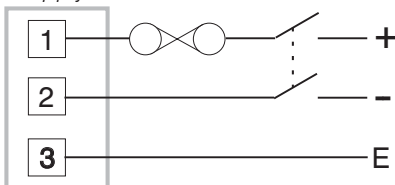

### Please note:

The unit cannot be changed by the user from one type of power supply version to

another. This conversion can only be done on a return to factory basis.

## Fuse replacement and changing supply voltage

### Gaining access to power supply



**WARNING:** Switch off all supplies and isolate signal and other wiring from dangerous voltages before proceeding.

- (i) Remove plug-in module as described in Access to Terminals in the Installation section.
- (ii) The plate with the terminal connections label can now be removed by easing apart the longer sides of the module to release the interlocking tongue and groove.
- (iii) Note the location of the printed circuit board which must be replaced in the same position. Slide out the board.

*Continued >*

## Changing AC supply voltage

Mains powered units can be adapted for operation on 110V, 200V, 220V or 240V supplies. Fig 1 provides details of the required link settings which are effected by soldered tinned copper wire links.



**WARNING:** Links for 200V operation must be insulated with silicon rubber sleeving.

## DC powered versions

The operating supply voltage on DC powered units cannot be changed by the user. This conversion can only be done on a return to factory basis.

## Fuse replacement

The fuse holder is located at the edge of the circuit board and above the mains transformer or DC power unit.

**Fuse size:** 20mm x 5mm dia.

**Fuse ratings:**

*AC Supply* - 100mA Quick Blow

*DC Supply* - 250mA Anti-surge

## Re-assembly

Re-check your link selections.

Replace the printed circuit board into the case ensuring that it is located in the slot under the LED indicator window. Replace the bottom plate by first engaging the side with the two tongues into the slots in the case and then press the plate home to engage the side with the single tongue. Plug the reassembled module into the base section and secure with the two captive screws provided - *do not overtighten*.

Fig. 1 AC mains supply links

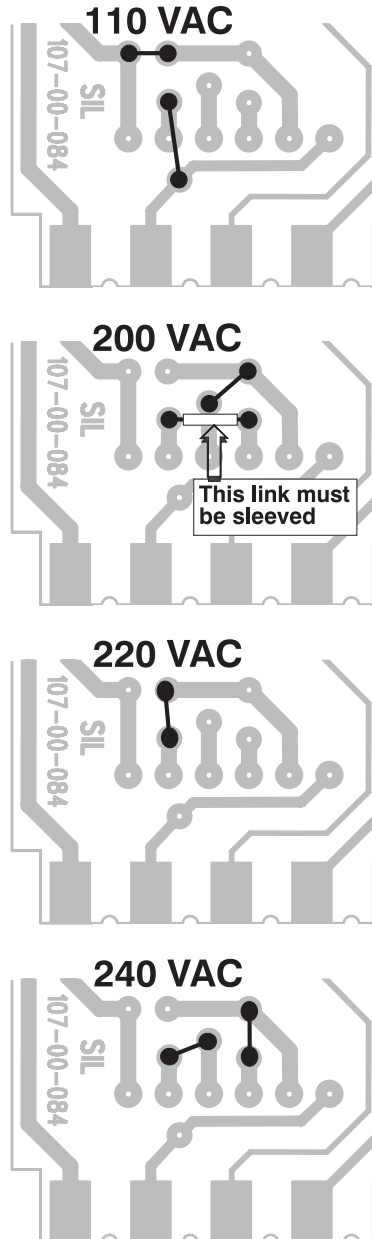

# SPECIFICATION

## GENERAL NOTE

The 107-18 can be manufactured for other input and output ranges. Please contact our sales department for details.

## INPUTS

### mA Ranges

*Input impedance  
(ohms)*

0-10mA	390
0-20mA	200
4-20mA	240

### Voltage Ranges

0-5v / 1-5v into greater than 100 k ohms

## OUTPUTS

0-10 mA into 2000 (5000\*) ohms max.

0-20 mA into 1000 (2500\*) ohms max.

4-20 mA into 1000 (2500\*) ohms max.

0-5v into 500 ohms min.

1-5v into 500 ohms min.

Current Sink 4- 20 mA @ 50 Volts max.

*\* available options*

### RATE OF CHANGE (for full scale output)

Minimum: 5% of input/minute

Maximum: 500% of input /minute

### ERROR (in rate for full scale output)

5% maximum

### OUTPUT RIPPLE

≤ 0.1% (peak to peak) of FSD

### LOAD RESISTANCE EFFECT

≤ 0.001% of span/100 ohm change.

## ISOLATION

The input and output are not isolated from each other, but are isolated from the power supply.

## TEMPERATURE COEFFICIENTS

Zero: ± 0.03% span/ °C

Span: ± 0.03% span/ °C

## TEMPERATURE RANGE

Operating: -10 °C to + 60 °C

Storage: -20 °C to + 70 °C

## SUPPLY VOLTAGE REJECTION

Output change <0.01% span/ % supply change.

## POWER SUPPLY

A LED indicates when the power supply is connected.

### Standard AC:

110, 220 or 240V ±10% 50/60Hz; 5VA

Fuse (internal) 100mA quick-blow (20 x 5mm)

### Optional DC:

12, 24 or 48V -10% to + 20%; 3.5W

Fuse (internal) 250mA anti-surge (20 x 5mm)

## ENCLOSURE DETAILS

Base: Phenol (black)

Cover: Polystyrol (light grey)

Protection: IP40

## WEIGHT

Approximately 0.5 kg