



SIGNAL ISOLATORS

Single Output • Dual Output

B12 SERIES

- **Single and Dual output versions**
- **Low-cost 3 or 4 port isolation**
- **Wide range of input & output ranges**
- **Current sink or source**
- **Features span & zero controls**
- **Scaling of process values**
- **AC or low voltage (11-32 VDC, 12-24VAC) powered versions**
- **Wall or DIN rail mounting**

This range of instruments provide cost-effective signal booster, signal converter or signal splitter functions. The input, outputs and power supply are electrically isolated from each other making these units ideal for preventing or solving erratic measurements due to earth loops. Outputs on dual version may be of different types.

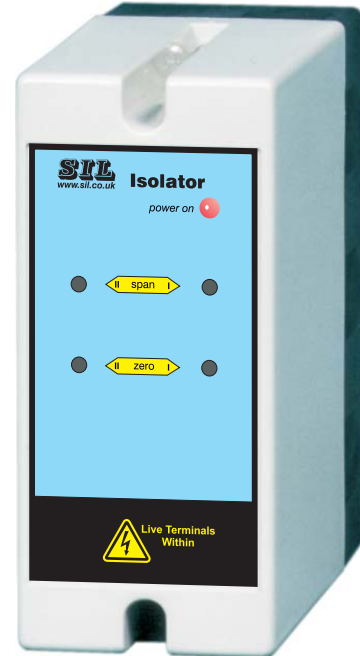

TYPICAL APPLICATIONS

- Overcoming problems where a common mode voltage exists between the input and output.
- Solving current loop loading problems.
- Isolating and converting dangerous voltages to safe levels.
- Converting voltage signals to current or current signals to voltage.
- Interfacing field sensors, transducers and transmitters with indicators, PLCs, and other process control instrumentation.
- The dual output version enables one measurement to be sent to two independent systems.

Ordering Information

- Isolator Type
 - B12-SI** Single Output
 - B12-SI/2** Dual Output
- Input Signal
- Output 1 Signal, Output 2 Signal (dual output type)
- Supply Voltage and Frequency
- Wall or DIN Rail Mounting

DIMENSIONS

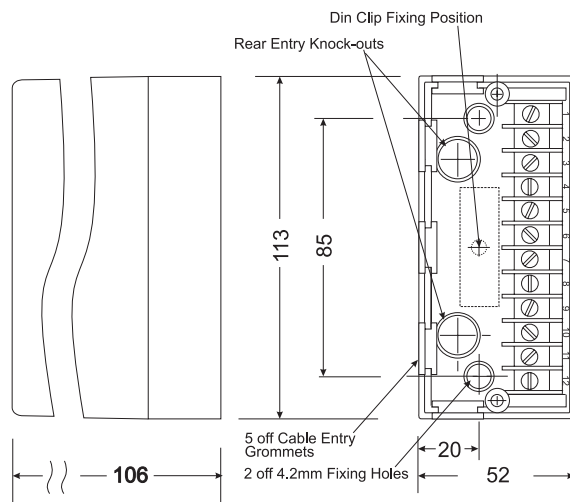

SPECIFICATION

INPUT

B12 Isolators with mA inputs are supplied with a facility that maintains the input signal loop when the instrument is unplugged from its base section.

0-10 mA into 100 ohms
0-20 mA into 50 ohms
4-20 mA into 62 ohms
0-5v into greater than 200 k ohms
1-5v into greater than 200 k ohms

N.B. Inputs other than those listed can be catered for.

OUTPUTS

0-10 mA into 1200 ohms max.
0-20 mA into 600 ohms max.
4-20 mA into 600 ohms max.
0-5v into 500 ohms minimum
1-5v into 500 ohms minimum
Current sink 4-20mA @ 50 volts max.

N.B. Outputs other than those listed can be provided.

ISOLATION

The input and output(s) are isolated from each other and from the power supply.
Maximum Voltage 250V RMS or 400V DC
Resistance between input, output(s) or power supply $\geq 50 \times 10^6$ ohms measured at 1000V DC.

CALIBRATED ACCURACY

Set at 100% to be within $\pm 0.1\%$ FSD

LINEARITY ERROR

$\leq \pm 0.1\%$ FSD

SUPPRESSION / ELEVATION ERROR

$\leq \pm 0.1\%$ FSD

OUTPUT RIPPLE

$\leq 0.2\%$ RMS of FSD

LOAD RESISTANCE EFFECT

$\leq 0.001\%$ of span / 100 ohm change

STABILITY

Over 24 hours $\pm 0.1\%$ FSD
Over 1 year $\pm 0.25\%$ FSD

INTERFERENCE REJECTION

Filtering is incorporated to attenuate R.F. and other industrial noise.

SERIES MODE AC REJECTION RATIO

For 50/60Hz series mode signals with p.t.p. amplitude \leq input; rejection ratio greater than 40dB.

RESPONSE TIME

1 sec as standard.

COMMON MODE REJECTION

$<0.2\%$ error for 250V RMS 50/60 Hz, or 400V DC, common mode signals.

INPUT OVERRANGE PROTECTION

Voltage Inputs: 250 volts RMS or DC
Current Inputs: 50mA

TEMPERATURE COEFFICIENTS

Zero: $\pm 0.02\%$ span / °C
Span: $\pm 0.02\%$ span / °C

TEMPERATURE RANGE

Operating: -10°C to $+60^\circ\text{C}$
Storage: -20°C to $+70^\circ\text{C}$

SUPPLY VOLTAGE REJECTION

Span change: $<0.02\%$ span / % supply change.

POWER SUPPLY

AC Supply: 110, 220 or 230V $\pm 10\%$ 50/60Hz 5VA
Fuse: 100mA quick-blow (internal)
Low voltage: 11-32VDC 4 W / 12-24VAC
Fuse: 250mA anti-surge (internal)

WEIGHT

Approx. 0.5kg

SAFETY & EMC

Safety: EN61010-1
Immunity: EN50082-1
Emissions: EN50081-1
CE certified

ELECTRICAL CONNECTIONS



WARNING: these details are provided for pre-sales information only. Installation must be carried out in accordance with the User Guide

Inputs

- 1 no internal connection
- 2 Input Signal (+)
- 3 Input Signal (-)

Output 2 (Available on B12-SI/2 dual output version only)

- | | |
|----------------------|--------------|
| 4 Output (+) | Current Sink |
| 5 Current Output (-) | 5 (+) |
| 6 Voltage Output (-) | 6 (-) |

Output 1

- | | |
|----------------------|--------------|
| 7 Output (+) | Current Sink |
| 8 Current Output (-) | 8 (+) |
| 9 Voltage Output (-) | 9 (-) |

Supply

- | | | | |
|------------|-------------------|------------------------------------|--------------------|
| 10 Earth | } AC Mains Supply | Earth Negative (-)
Positive (+) | } DC Supply Option |
| 11 Neutral | | | |
| 12 Line | | | |



THIS UNIT CAN BE MAINS POWERED, AND ALL INPUTS TO IT MUST BE ISOLATED FROM DANGEROUS VOLTAGES BEFORE THE FRONT COVER IS REMOVED. LIVE TERMINALS WILL BE EXPOSED.

Continuous development may necessitate changes in these details without notice

SIL

STROUD INSTRUMENTS LTD.
36-40 Slad Road, Stroud, Glos. GL5 1QW, England
Telephone: +44 (0)1453 765433 Fax No: +44 (0)1453 764256
www.sil.co.uk