



SIGNAL CONVERTER

TYPE 160-1

FUNCTION

The 160-1 will convert a variety of input signals, (e.g. voltage, current or resistance) into isolated standard transmission signals.

DESCRIPTION

The unit is configured during manufacture to suit the required input and output signals. The input circuit provides amplification and level shifting. An output amplifier stage provides an isolated, load independent, current or voltage output signal. Output signals can be live-zero or true-zero types. The output can also be configured in a current sink mode where the output stage will sink current from an external power source.

Zero and span controls are provided which are accessible from the front of the unit after removing plastic plugs. These controls enable 'on-site' adjustments which may be necessary for certain versions, e.g. resistance inputs.

Current and Voltage Inputs: The input circuit can accommodate a variety of signal levels. Bi-directional (e.g. $\pm 5V$), reverse (e.g. 0 to $-10V$), true zero and live zero (e.g. 4-20mA) signals can be accepted. The chopper stabilised high gain amplifier input will also accommodate milli-volt inputs.

As an option, the 160-1 provides a transducer power supply output of up to 24 volts at 20mA e.g. to power a 4-20mA loop.

Resistance Inputs: A constant current supply is provided for external resistance type transducers. The unit can be configured for 2, 3 and 4 wire resistance transducers including variable resistors, potentiometers, resistance temperature detectors (RTDs) and bridge configurations (e.g. strain gauges).

A front panel 'LED' indicator is illuminated when power is applied to the unit.



Features

- * **Current, Voltage, Milli-volt, or 2/3/4 Wire Resistance Inputs**
- * **Accepts Live-zero, True-zero, Bi-directional or Reverse Input Signals**
- * **Isolated Current or Voltage Output (Including Current Sink Option)**
- * **Optional Transducer / Loop Power Supply**

Information Required When Ordering

- Input Signal (see specification overleaf)
- Type of Output (see specification overleaf)
- Voltage for Transducer / Current Loop Power Supply Option.
- Supply Voltage and Frequency

SPECIFICATION

INPUTS (others can be provided)

Milli-volt:

Spans in the range 4 to 1000mV.

Current:

0 - 10mA into 100 ohms.

0 - 20 mA into 50 ohms.

4 - 20 mA into 62R5 ohms.

Voltage:

0-5 Volts into > 200 k ohms.

± 5 Volts into > 200 k ohms.

Resistance:

Minimum change 50 ohms.

Maximum change 10k ohms.

Resistance Thermometers:

100 or 130 ohms.

Minimum span 40 °C.

Maximum span 500 °C.

OUTPUTS (others can be provided)

0 - 10 mA. into 2000 ohms maximum.

0 - 20 mA into 1000 ohms maximum.

4 - 20 mA into 1000 ohms maximum.

Current sink 4 - 20 mA @ 50 Volts maximum.

0 - 5 Volts into 500 ohms minimum.

1 - 5 Volts into 500 ohms minimum.

0 - 10 Volts into 1 k ohms minimum.

CALIBRATED ACCURACY

Set at 100 % to be within ± 0.1% FSD.

LINEARITY ERROR (does not linearise input transducers)

≤ ± 0.1% FSD.

SUPPRESSION / ELEVATION ERROR

≤ ± 0.1% FSD.

OUTPUT RIPPLE

≤ 0.2% RMS of FSD.

LOAD RESISTANCE EFFECT

≤ 0.001% of span per 100 ohms change.

ISOLATION

The input, output and power supply are all isolated from each other.

Maximum voltage: 250V RMS, or 400Vdc.

Resistance between input, output, or power supply ≥ 50 x10⁶ ohms measured at 1000V dc.

INTERFERENCE REJECTION

Filtering is incorporated to reject R.F. and other industrial noise.

SERIES MODE AC REJECTION RATIO

Rejection ratio ≥ 40dB. for 50/60 Hz series mode signals with p.t.p. amplitude < 50% span.

COMMON MODE REJECTION

250V 50/60 Hz or 400V dc common mode inputs give ≤ 0.2% span error.

INPUT OVER-RANGE PROTECTION

Voltage inputs: 250V RMS. or d.c.

Current inputs: 0.5W maximum.

Resistance and mV inputs: 12V d.c. maximum.

TEMPERATURE COEFFICIENTS

Zero: ± 0.02% span / °C.

Span: ± 0.02% span / °C.

STABILITY

Over 24 hours: ± 0.05% FSD.

Over 1 year: ± 0.2% FSD.

TEMPERATURE RANGE

Operating: -10 °C to +60 °C.

Storage: -20 °C to +70 °C.

SUPPLY VOLTAGE REJECTION

Output change ≤ 0.01%span / % supply change.

POWER SUPPLY

Standard AC and optional DC powered versions are available. Full details of the power supply options are given in the 160 Series General Information Sheet.

Power Supply Indication: A front panel 'LED' indicator is illuminated when power is applied to the unit.

Fuse: This unit is fused internally.

MODULE WIDTH

7HP (See 160 Series General Information Sheet)

WEIGHT

Approximately 0.5kg.

TERMINAL CONNECTIONS

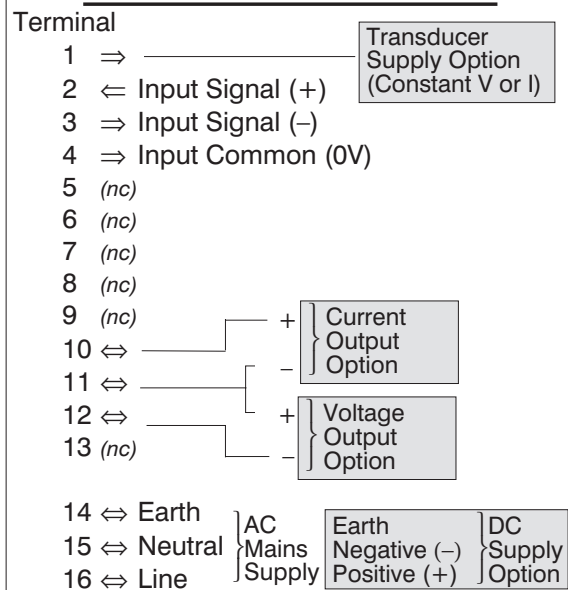

Please Note: Options are only available if specified at time of order.

WARNING THIS UNIT CAN BE MAINS POWERED, AND ALL INPUTS TO IT MUST BE ISOLATED FROM DANGEROUS VOLTAGES BEFORE WITHDRAWING THE UNIT FROM ITS RACK OR ENCLOSURE.



Continuous development may necessitate changes in these details without notice

SIL

STROUD INSTRUMENTS LTD.

36-40 Slad Road, Stroud, Glos. GL5 1QW, England

Telephone: +44 (0)1453 765433 Fax No: +44 (0)1453 764256

www.sil.co.uk