



DIGITAL DIVIDER

TYPE 112-25

- * **User selectable division**
- * **Wide range of input signal types**
- * **Voltage pulse, relay or open collector outputs**
- * **Isolated output**
- * **Wall or DIN rail mounting**

The 112-25 divides the frequency of the input signal by an adjustable integer. The instrument caters for a wide range of input signal types including, voltage levels, mechanical switches, proximity switches and flow sensors. Outputs include voltage pulse, relay and open collector types.

Two versions are available. The 112-25/2 provides two-decades of division (0-99) selectable via internal switches. The 112-25/4 provides four-decades of division (0-9999) selectable via internal switches and a further $\div 10$ or $\div 100$ selectable by a jumper link.

TYPICAL APPLICATIONS

Flowmeter scaling: pulse output from meter can be scaled to give one pulse per unit volume.

Conveyor batch counting: items passing along a conveyor belt can be counted and tipped into a box after the preset number has been counted.



Information required when ordering

- Input signal type (see specification)
- Type of output (see specification)
- Desired pulse width for open collector output option (if standard 60ms is not required).
- Transducer power supply
- Supply voltage and frequency
- Whether DIN rail mounting clip is required

DIMENSIONS

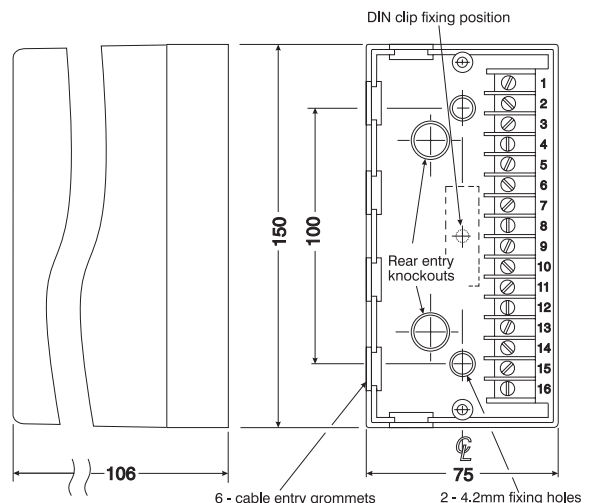

SPECIFICATION

INPUTS

The required type to be specified at the time of order.

- Contact closure
- Change-over contacts (high bounce rejection)
- Voltage level change (10mV minimum, 50V maximum. sine, square or triangular)
- Open collector transistor
- Proximity switches, turbine meters, etc.

INPUT PULSE RATE

0-20kHz

INPUT IMPEDANCE

100k ohms (voltage change signals).

TRIGGER LEVEL

This is adjusted by a 15 turn potentiometer accessible through the front panel.

NB not fitted for turbine meter inputs.

When the trigger level is correctly set, the lower LED will flash at the input signal frequency.

INPUT PROTECTION

Voltage change inputs, can withstand 250V RMS.

TRANSDUCER POWER SUPPLY

Up to 12 Volts at 10mA max.available (Optional).

OUTPUT OPTIONS

The required type to be specified at the time of order.

- Optically isolated open collector transistor,
- 24 Volt pulse of duration 60ms
(E.M. counter output *NB* the counter used must have an impedance ≥ 80 ohm)
- Relay change-over contact (FSD = 10Hz max).
Relay contacts are rated at:-
5A @ 250V AC resistive or 2.5A @ 24V DC resistive
- Other pulse output voltages (e.g. 5V) and pulse widths available to order.

TEMPERATURE RANGE

Operating: - 10 to + 60°C

Storage: - 20 to + 70°C

ACCURACY

Error $\leq \pm 1$ output pulse.

ISOLATION

Input and output are isolated from each other and from the power supply.

Maximum voltage 50 V RMS or 400 V DC.

Resistance $\geq 50 \times 10^6$ ohms measured at 1000 V DC.

POWER SUPPLY

LED indication of power on.

Standard AC: 110, 220 or 240V $\pm 10\%$ 50/60Hz; 5VA

Fuse (internal) 100mA quick-blow (20 x 5mm)

Optional DC: 12, 24 or 48V -10% to + 20%; 3.5W

Fuse (internal) 250mA anti-surge (20 x 5mm)

WEIGHT

Approximately 750 grams.

SAFETY & EMC

Safety: EN61010-1; Immunity: EN50082-1

Emissions: EN50081-1; CE certified

DIVISION SETTING

Type 112-25 /2 - two decade switches maximum division of 99

Type 112-25 /4 - four decade switches division of 9999, and link selection of further divisions of either $\div 10$ or $\div 100$.

TERMINAL CONNECTIONS

Inputs

- Transducer Supply (option)
- Input Signal (+)
- Input Signal Common (-)
- Normally Closed c/o Switch Contact
- Normally Open c/o Switch Contact
- (no connection)

Outputs

- +V
- Output
- Output Com
- SPCO Normally Open
- SPCO Common
- SPCO Normally Closed
- (no connection)

Supply

- Earth
- Neutral
- Line

AC
Mains
Supply

Earth
Negative (-)
Positive (+)

DC
Supply
Option

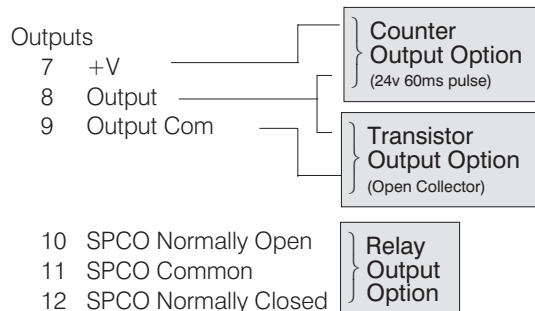

Please Note: Options are only available if specified at time of order.



THIS UNIT CAN BE MAINS POWERED, AND ALL INPUTS TO IT MUST BE ISOLATED FROM DANGEROUS VOLTAGES BEFORE THE FRONT COVER IS REMOVED. LIVE TERMINALS WILL BE EXPOSED.

Continuous development may necessitate changes in these details without notice

SIL

STROUD INSTRUMENTS LTD.
36-40 Slad Road, Stroud, Glos. GL5 1QW, England
Telephone: +44 (0)1453 765433 Fax No: +44 (0)1453 764256
www.sil.co.uk